

THE NEW VALUE FRONTIER



KC125GHT-2

HIGH EFFICIENCY POLYCRYSTALLINE PHOTOVOLTAIC MODULE



Kyocera is "ISO9001" certified and registered.
TUVdotCOM Internet platform for tested quality and service ID 000006186.

HIGHLIGHTS OF KYOCERA PHOTOVOLTAIC MODULES

Kyocera's advanced cell processing technology and automated production facilities produce a highly efficient polycrystalline photovoltaic module.

The conversion efficiency of the Kyocera solar cell is over 16%.

These cells are encapsulated between a tempered glass cover and an EVA pottant with back sheet to provide efficient protection from the severest environmental conditions.

The entire laminate is installed in an anodized aluminum frame to provide structural strength and ease of installation. Equipped with plug in connectors.

APPLICATIONS

Grid-Connected Systems

- Residential Solar Power Systems
- Public and Industrial Solar Power Systems

Stand-Alone Solar Power Systems for

- Villages in remote areas
- Homes and summer cottages
- Microwave / Radio repeater stations
- Medical facilities in rural areas

- Emergency communication
- Water quality and environmental data monitoring
- Drinking water and livestock water pumping
- Small-scale irrigation pumping
- Cathodic protection
- Aviation obstruction lights
- Environmental data monitoring
- Railway signals
- Street lighting
- Small-scale desalination

LIMITED PERFORMANCE WARRANTY

- 2 years limited warranty on material and workmanship
- 25 years limited warranty on power output.

(Long term output warranty shall guarantee that loss of output is not more than 10% of the minimum warranty value of the product specifications within 12 years and is not more than 20% within 25 years after the purchase of the product by customer. The output values shall be those measured under Kyocera standard measurement conditions. Regarding the warranty conditions in detail, please refer to Warranty issued by Kyocera.)

ELECTRICAL CHARACTERISTICS

Current-Voltage characteristics of Photovoltaic Module KC125GHT-2 at various cell temperatures

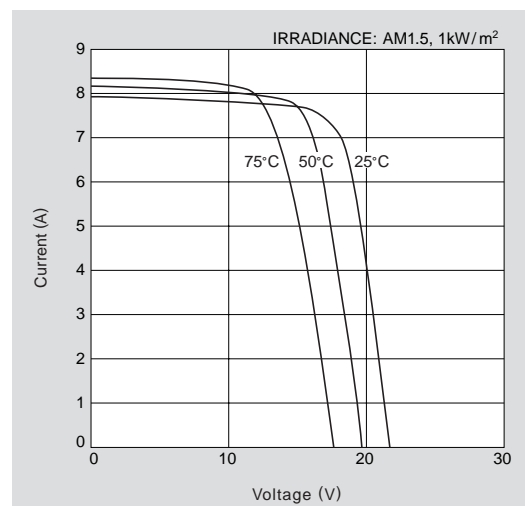

Current-Voltage characteristics of Photovoltaic Module KC125GHT-2 at various irradiance levels

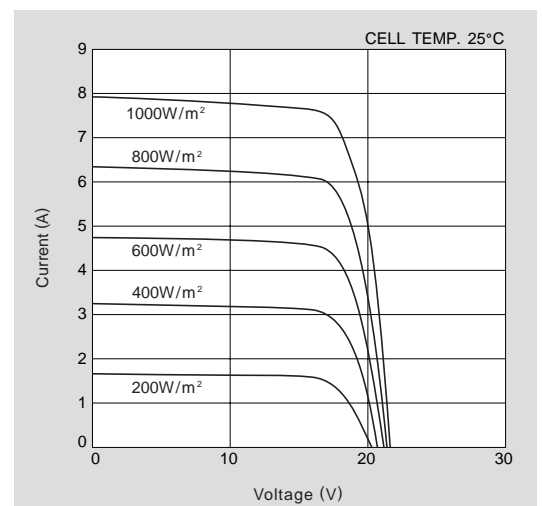

MODEL
KC125GHT-2

SPECIFICATIONS

Physical Specifications

(Unit : mm)

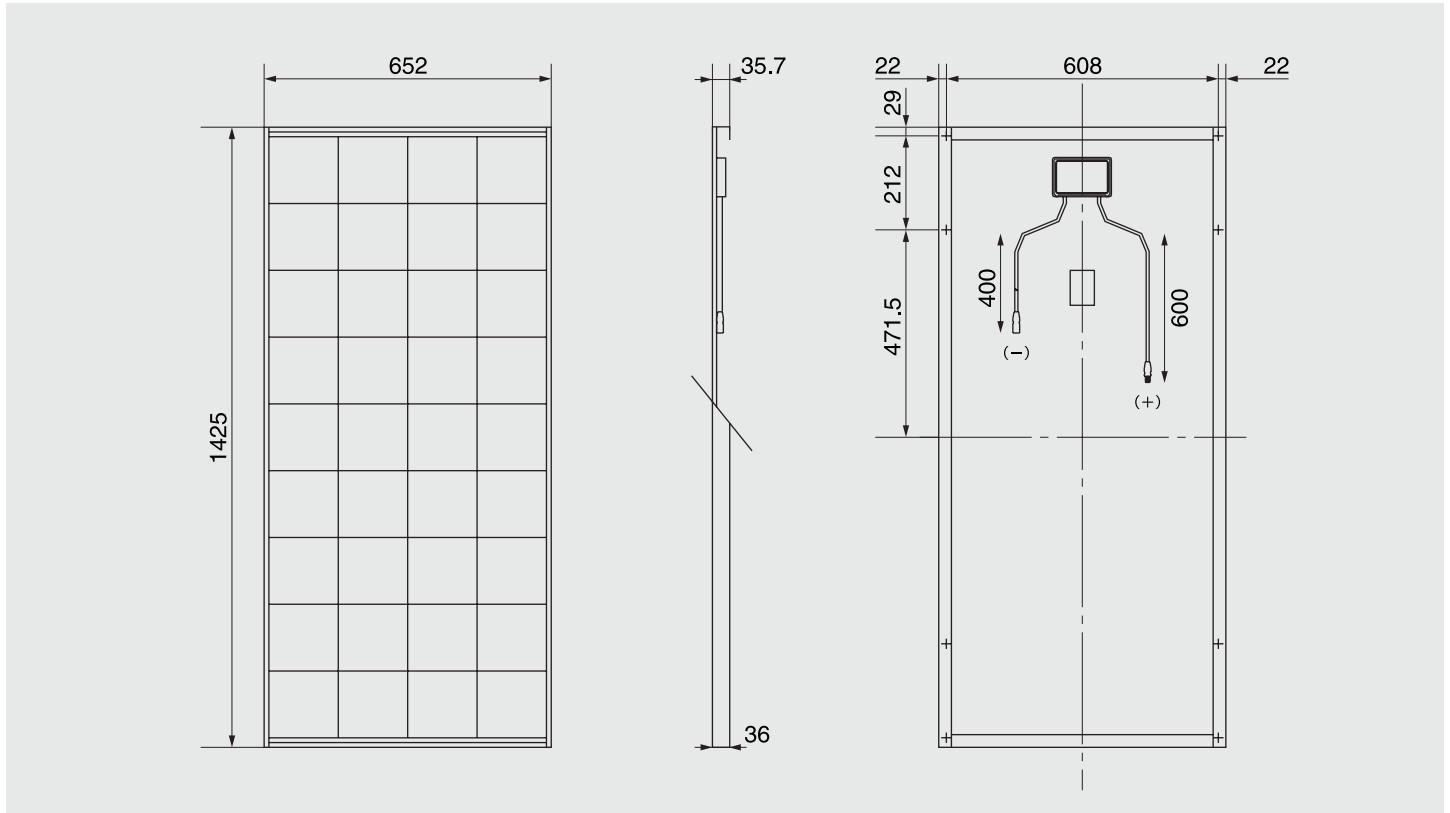

Specifications

Electrical Data		
Maximum Power(Pmax)	[W]	125
Tolerance	[%]	+10/-5
Maximum Power Voltage	[V]	17.4
Maximum Power Current	[A]	7.20
Open Circuit Voltage (Voc)	[V]	21.7
Short Circuit Current (Isc)	[A]	8.00
Temp. coefficient of Voc	[V/°C]	-8.21×10 ⁻²
Temp. coefficient of Isc	[A/°C]	3.18×10 ⁻³
NOCT	[°C]	47
Max System Voltage	[V]	1000

Dimension		
Length	[mm]	1425
Width	[mm]	652
Depth without box	[mm]	36
Weight	[kg]	12.2
Cable	[mm]	(+)600/(-)400

Cells	
Number per module	36
Cell Technology	Polycrystalline
Cell Shape	Rectangular

Note : The electrical specifications are under test conditions of Irradiance of 1kw/m², Spectrum of 1.5 air mass and cell temperature of 25°C.
Kyocera reserves the right to modify these specifications without notice.

Please contact our office to obtain details without hesitation.



KYOCERA Corporation

■ KYOCERA Head Office
 CORPORATE SOLAR ENERGY DIVISION
 6 Takeda Tobadono-cho
 Fushimi-ku, Kyoto
 612-8501 Japan
 Phone:(81)75-604-3476 Telefax:(81)75-604-3475
<http://www.kyocera.com>

● **KYOCERA Fineceramics GmbH**

Fritz-Mueller-Str. 107, 73730 Esslingen, Germany
 Phone:(49)711-93934-17, Telefax:(49)711-93934-50
<http://www.kyocerasolar.de>
 E-mail:solar@kyocera.de

● **KYOCERA Asia Pacific Pte. Ltd.**

298 Tiong Bahru Road, #13-03/05
 Central Plaza, Singapore 168730
 Phone:(65)271-0500 Telefax:(65)271-0600

● **KYOCERA Solar, Inc.**

7812 East Acoma Drive
 Scottsdale, AZ 85260
 Phone:(480)948-8003 or (800)223-9580 Telefax:(480)483-6431
<http://www.kyocerasolar.com>

● **KYOCERA(Tianjin) Sales & Trading Corporation**

Binjiang International Hotel 1106
 105 Jianshe Road Heping Dist. Tianjin China
 TEL:(22)2331-8590
 FAX:(22)2330-6276